

Revised to total total area excess land

8/31/11

EXHIBIT "A"

Project: STP-S050(007)

Code: 3786

Parcel 141 Excess Land

St. Joseph County Parcel No.: 18-5030-1087

Tax ID Key: 71-08-01-431-005.000-026

A part of Lot A as shown on the recorded plat of Benny Kirk's Minor Subdivision First Replat, recorded as Instrument Number 0018796 in the Office of the Recorder of St. Joseph County, Indiana, being that part of the grantor's land lying within the right of way lines depicted on the attached Right Of Way Parcel Plat, marked EXHIBIT "B", described as follows: Commencing at the southwesterly corner of said Lot A, designated as point "354" on said Parcel Plat; thence South 89 degrees 59 minutes 03 seconds East, (Indiana State Plane Coordinates, East Zone), along the southerly boundary of said lot, a distance of 36.47 feet, to point "355" as designated on said Parcel Plat and being the Point of Beginning of this description; thence North 64 degrees 40 minutes 20 seconds East, a distance of 23.81 feet, to a point designated as "366" on said Parcel Plat; thence North 84 degrees 05 minutes 50 seconds East, a distance of 162.08 feet to a point on an easterly boundary of said Lot A, being South 00 degrees 47 minutes 05 seconds E, along said easterly boundary, a distance of 0.36 feet from a northeasterly corner of said Lot A, designated as point "364" on said Parcel Plat (the next 4 calls are along the easterly, southerly and westerly boundaries of said Lot A); South 00 degrees 47 minutes 05 seconds East, a distance of 54.64 feet, to point "529" as designated on said Parcel Plat; South 89 degrees 22 minutes 05 seconds West, a distance of 54.63 feet, to point "530" as designated on said Parcel Plat; North 00 degrees 31 minutes 53 seconds West, a distance of 28.35 feet, to point "359" as designated on said Parcel Plat; North 89 degrees 59 minutes 03 seconds West, a distance of 128.60 feet to the Point Of Beginning.

Containing 0.106 acres (4,634 square feet), more or less.

DATE: August 31, 2011

Ronald L. Nolan

RONALD L. NOLAN
Registered Land Surveyor SO 439
State Of Indiana



This description was prepared for the Indiana Department of Transportation by Ronald L. Nolan, Indiana Registered Land Surveyor, License Number LS80040439, on the 31st day of August, 2011.

EXHIBIT "B"

RIGHT-OF-WAY PARCEL PLAT
PREPARED FOR INDIANA DEPARTMENT OF TRANSPORTATION
BY WESSLER ENGINEERING

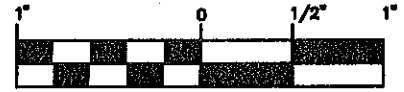

1 inch = 30 ft.

EQU:
P.I. 3+79.55, "S2A-PR"
= P.O.T. 30+86.43, "A"

RIGHT-OF-WAY
0.162 ACRES (7,041 SQ. FT.)±

CENTERLINE
CAMPEAU ST.
LINE S2A-PR

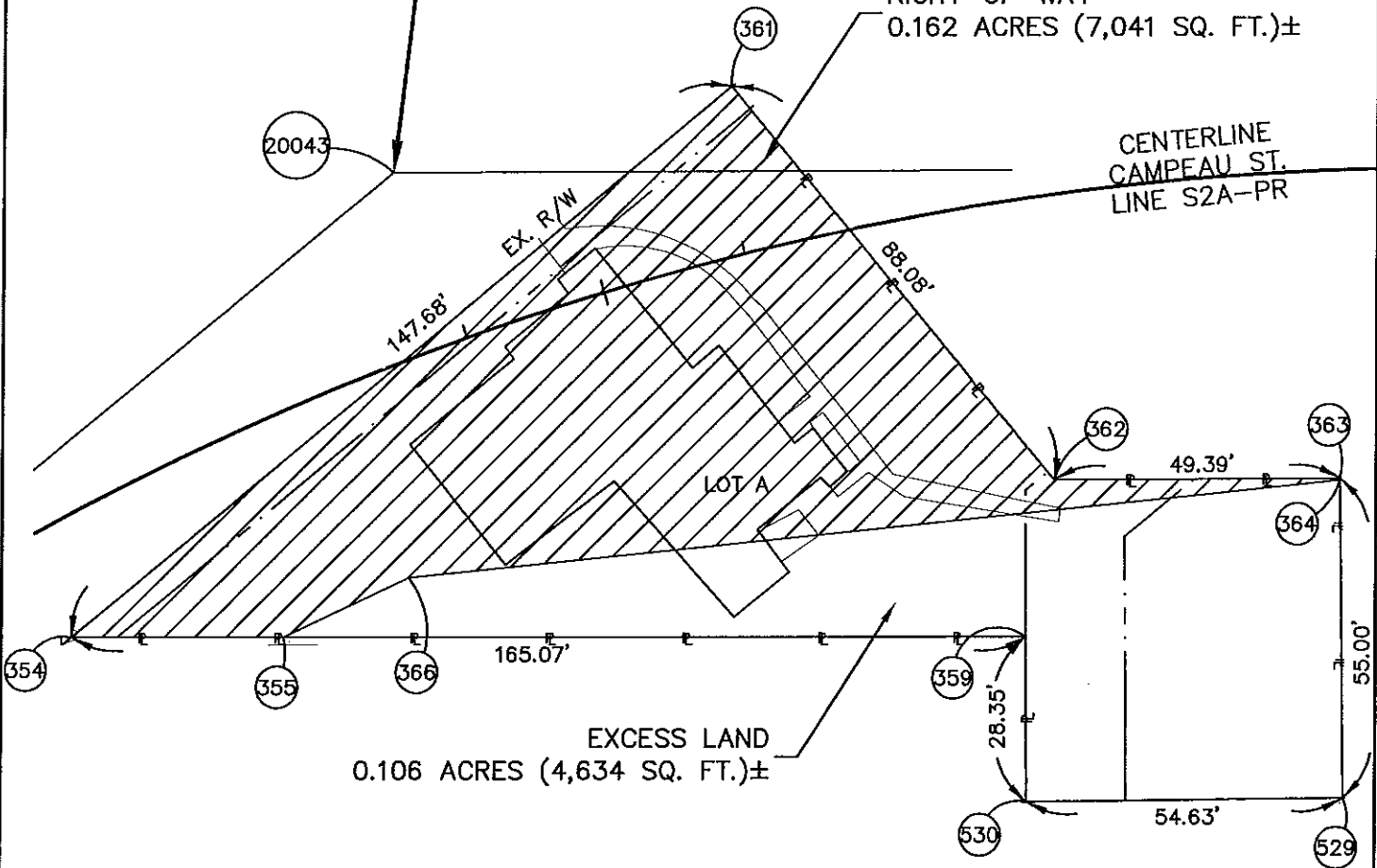

PARCEL: 141
CODE: 3786
PROJECT: STP-S050(007)
ROAD: S.R. 23
COUNTY: ST. JOSEPH
SECTION: 6
TOWNSHIP: 37-N
RANGE: 3-E

OWNER: CRIMMINS, JOSEPH R. & KATHLEEN C.

DRAWN BY: JNY 8-31-11
CHECKED BY: RLN 8-31-11
DES. NO.: 9133615



HATCHED AREA IS THE
APPROXIMATE TAKING

DEED INSTR. NO. 0152598, DATED 10-19-2001
KEY NO. 018-5030-1087

DIMENSIONS SHOWN ARE FROM THE ABOVE LISTED RECORDED DOCUMENTS.